

BENCH GRINDER SAFETY

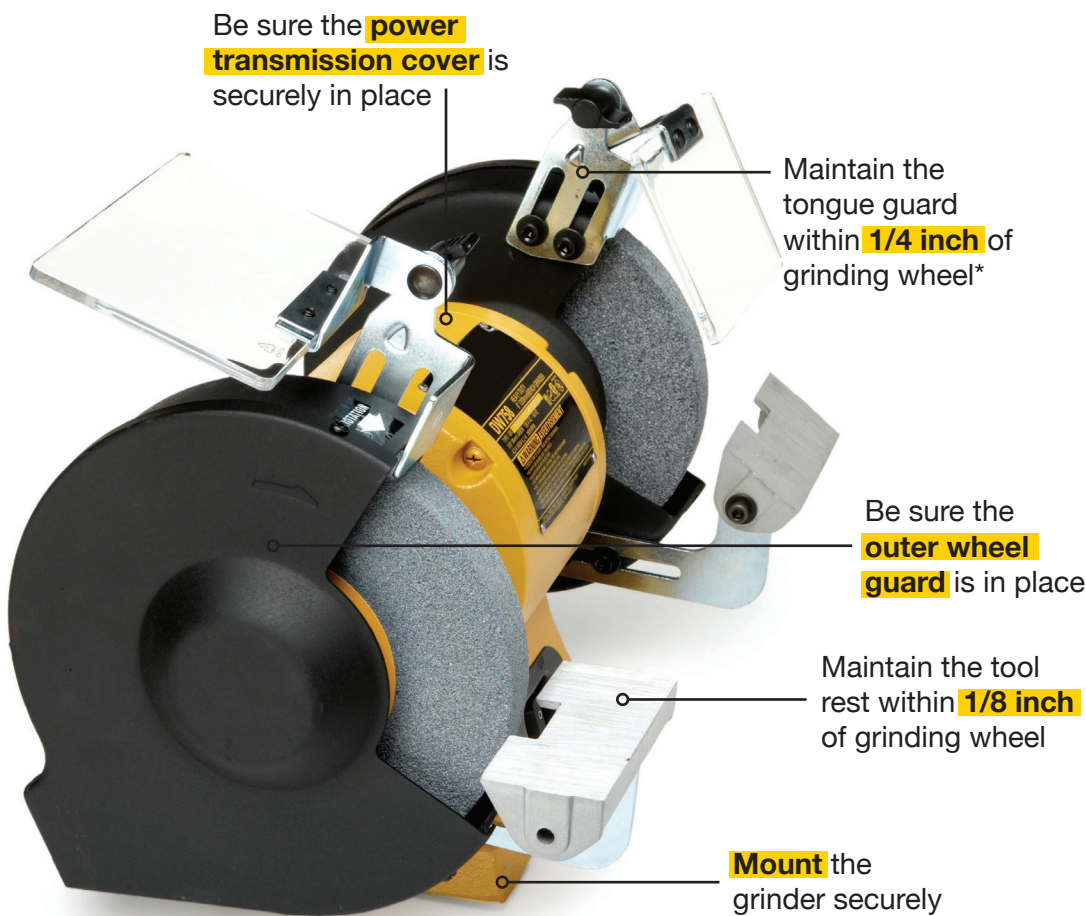

Make sure the manufacturer's **recommended speed**, as posted on the wheel, is compatible with your grinder



Always protect your eyes; wear only an eye or face shield bearing the logo Z-87



Do the Ring test:

Tap wheel 1-2" from periphery 45° each side of vertical with non-metallic screwdriver handle. Ring sound = good wheel, dull sound = cracked wheel and replacement of wheel required.

* As the wheel wears down, readjust the tool rest and tongue guard. When you can no longer adjust them, replace the wheel. **IMPORTANT:** When installing a new wheel, closely follow the manufacturer's instructions. An improperly installed wheel can break and cause an injury.

- Do not grind on side of wheel unless designed for side grinding
- Do not gouge wheel by grinding in one spot
- Do not grind aluminum, brass, copper or wood
- Check max rotational speed & ring test new wheel before installing.

For Additional Information, See 29 CFR1910.215.